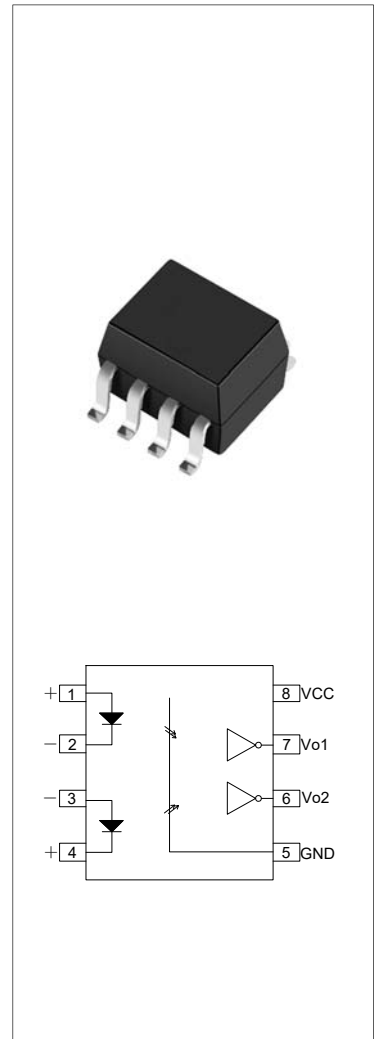




### DESCRIPTION:

The products are 10MBd high-speed opto-couplers in a plastic SOP8 package. The device consists of a high efficient AlGaAs Light Emitting Diode and a high speed optical detector. This design provides excellent AC and DC isolation between the input and output sides of the optocoupler. The output of the optical detector features an open collector Schottky clamped transistor. The enable function allows the optical detector to be strobed. The optocoupler operational parameters are guaranteed over the temperature range from -40°C~+110°C. The products are widely used in line receivers, data transmission, computer-peripheral interface, pulse transformer replacement and switching power supply.



### MAIN FEATURES

- High isolation 3750 VRMS
- High speed – 10MBd typical
- Operating temperature range -40°C to 110°C
- REACH & RoHS compliance
- HBM: H3A; MM: M4; CDM: C3
- CQC approved
- VDE approved
- UL approved

### Truth Table

LED	OUTPUT
ON	L
OFF	H

### ABSOLUTE MAXIMUM RATINGS (Temperature=25°C)

Parameter		Symbol	Value	Unit
Input	Forward Current	I <sub>F</sub>	50	mA
	Peak Forward Current	I <sub>FP</sub>	1 <sup>①</sup>	A

	Reverse Voltage	$V_R$	6	V
	Input Power Dissipation	$P_D$	100	mW
Output	Supply Voltage	$V_{CC}$	7	V
	Output Voltage	$V_O$	7	V
	Output Current	$I_O$	50	mA
	Output Power Dissipation	$P_O$	60	mW
Total Power Dissipation		$P_{tot}$	160	mW
Isolation Voltage		$V_{iso}$	3750 <sup>②</sup>	V <sub>rms</sub>
Operating Temperature		$T_{opr}$	-40~110	°C
Junction Temperature		$T_j$	125	°C
Storage Temperature		$T_{stg}$	-55~125	°C
Soldering Temperature		$T_{sol}$	260	°C

**NOTE1** : 100μs pulse, 100Hz frequency

**NOTE2** : AC for 1minute, R.H.=40~60%

### ELECTRICAL CHARACTERISTICS (Temperature=25°C)

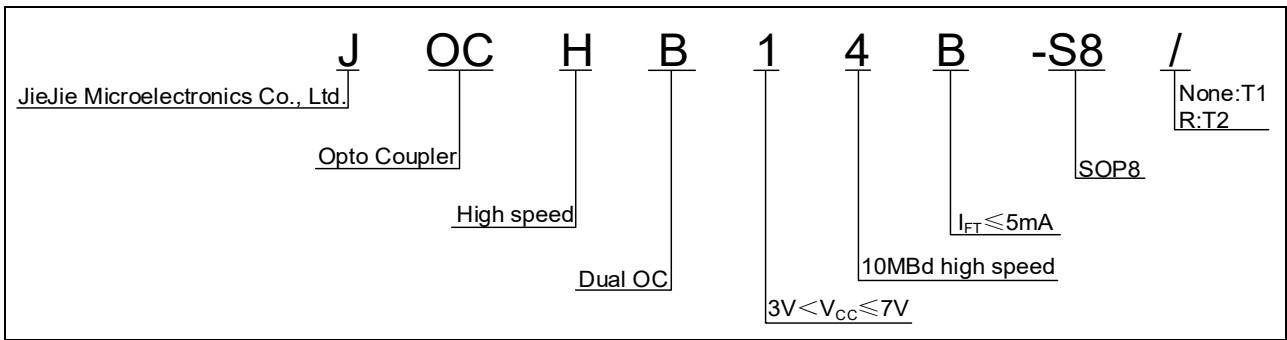
Parameter		Symbol	Condition	Min.	Typ.	Max.	Unit
Input	Forward Voltage	$V_F$	$I_F=10mA$	-	1.35	1.6	V
	Reverse Current	$I_R$	$V_R=6V$	-	-	1	μA
	Input Capacitance	$C_{in}$	$V=0, f=1MHz$	-	60	-	pF
Output	High Level Output Current	$I_{OH}$	$I_F=250\mu A,$ $V_{CC}=5.5V,$ $V_O=5.5V$	-	5.5	100	μA
	High Level Supply Current	$I_{CCH}$	$V_{CC}=5.5V,$ $I_F=0mA$	-	-	15	mA
	Low Level Supply Current	$I_{CCL}$	$V_{CC}=5.5V,$ $I_F=10mA$	-	-	21	mA
	Logic Low Output Voltage	$V_{OL}$	$I_F=5mA,$ $I_O=13mA,$ $V_{CC}=5.5V$	-	0.35	0.6	V
	Isolation Resistance	$R_{iso}$	DC500V 40~60%R.H.	$10^{12}$	-	-	Ω
	Floating Capacitance	$C_{IO}$	$V=0, f=1MHz$	-	0.6	-	pF

Switching Characteristics	Trigger LED Current	$I_{FT}$	$V_{CC}=5.5V$ $V_O=V_{OL}$	-	-	5	mA
	Propagation Delay Time to Logic Low	$t_{PHL}$	$C_L=15pF,$ $R_L=350\Omega,$ $I_F=7.5mA$	-	-	75	ns
	Propagation Delay Time to Logic High	$t_{PLH}$		-	-	75	ns
	Pulse width distortion	$ t_{PHL}-t_{PLH} $		-	-	35	ns
	Common Mode Transient Immunity at Logic High	$CM_H$	$V_{O(min.)}=2V,$ $I_F=0mA,$ $V_{CM}=10V_{p-p},$ $R_L=350\Omega$	15	-	-	kV/ $\mu s$
	Common Mode Transient Immunity at Logic Low	$CM_L$	$V_{O(max.)}=0.8V,$ $I_F=7.5mA,$ $V_{CM}=10V_{p-p},$ $R_L=350\Omega$	15	-	-	kV/ $\mu s$
	Rise Time	$t_r$	$C_L=15pF,$ $R_L=350\Omega,$ $I_F=7.5mA$	-	24	35	ns
	Fall Time	$t_f$		-	10	25	ns

**Recommended Operating Conditions**

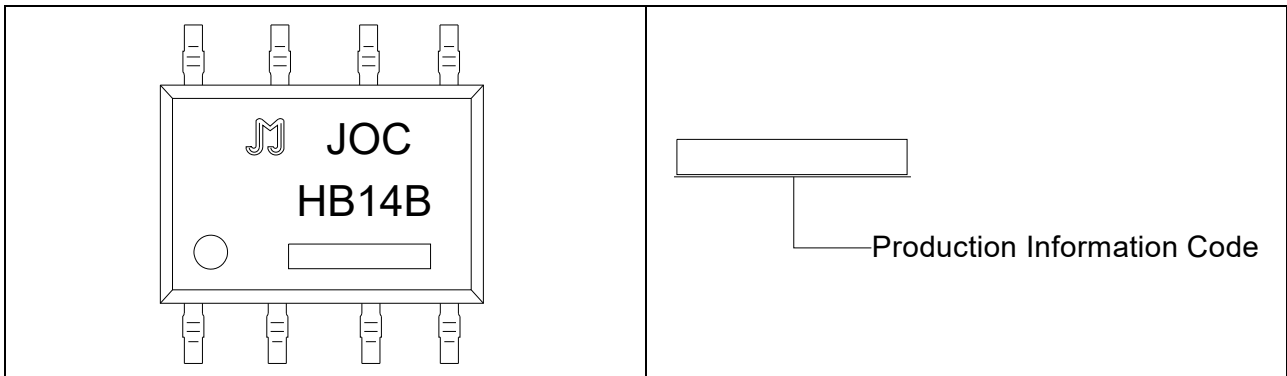
Characteristics	Symbol	Min.	Typ.	Max.	Unit
Low Level Input Voltage	$V_{FL}$	0	-	0.8	V
Supply Voltage	$V_{CC}$	2.7	-	3.6	V
		4.5	-	5.5	
Low Level Input Current	$I_{FL}$	0	-	250	$\mu A$
High Level Input Current	$I_{FH}$	7	-	20	mA
Output Pull-up Resistor	$R_L$	330	-	4k	$\Omega$
Fan Out (at $R_L=1k\Omega$ per channel)	N	-	-	5	TTL Loads

**ORDERING INFORMATION**



Packing Quantity	
Option	Quantity
SOP8	2000 Units/Reel

**MARKING**



Characteristics Curves

FIG.1: High Level Output Current vs. Ambient Temperature

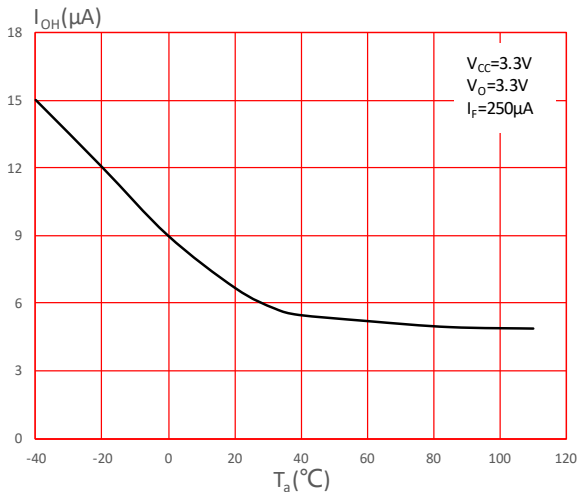


FIG.2: High Level Output Current vs. Ambient Temperature

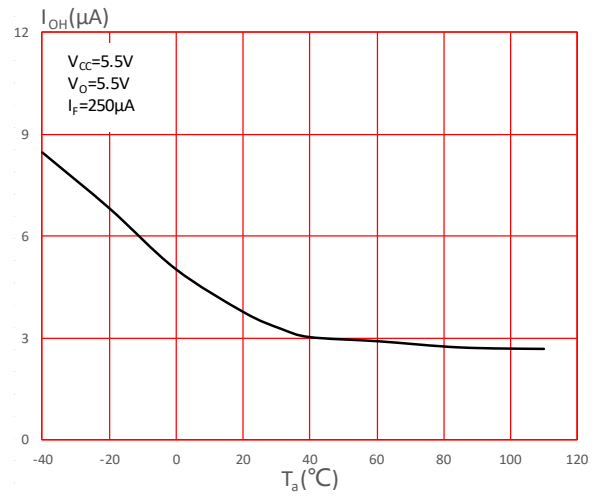


FIG.3: Input Threshold Current vs. Ambient Temperature

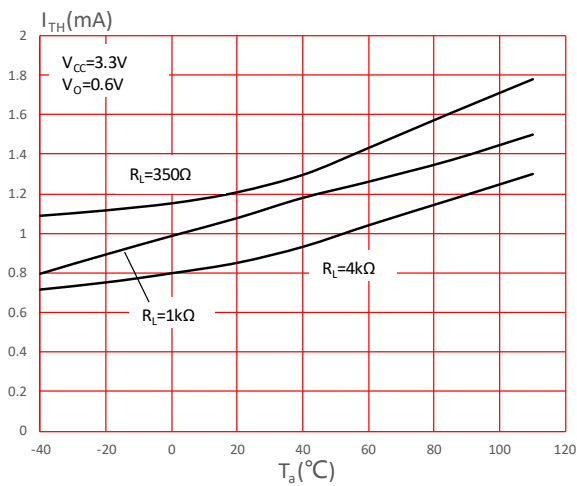


FIG.4: Input Threshold Current vs. Ambient Temperature

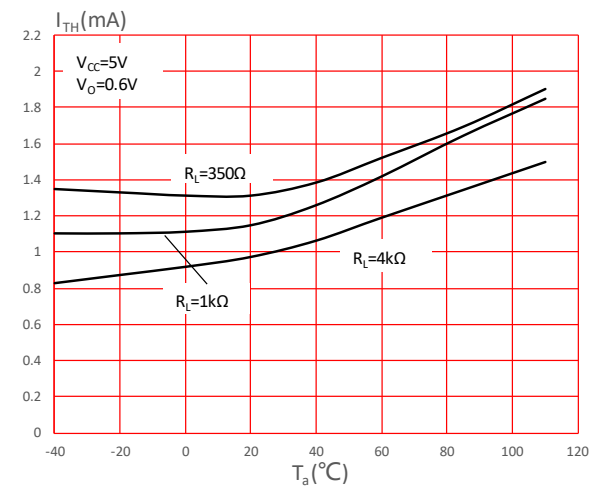


FIG.5: Low Level Output Voltage vs. Ambient Temperature

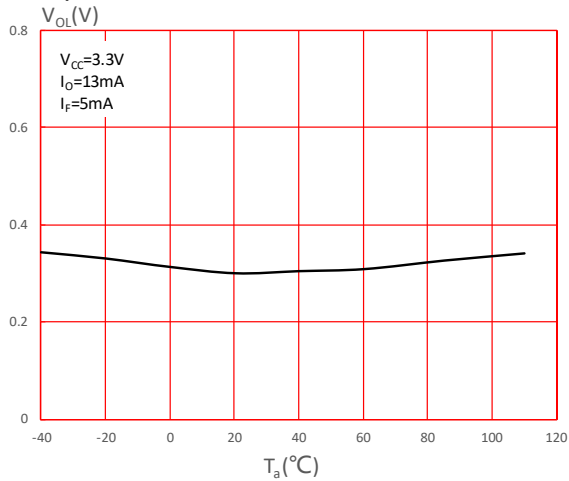
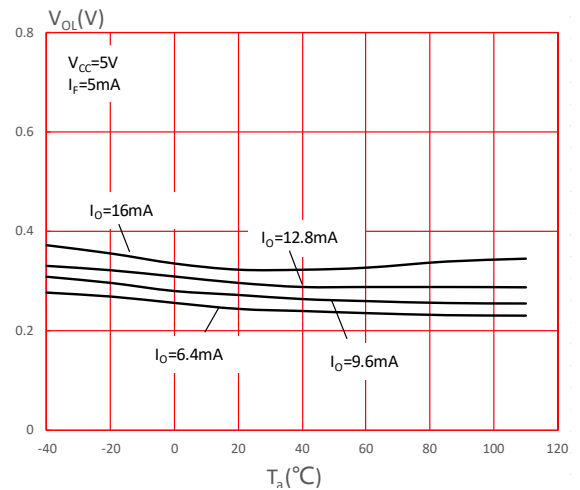
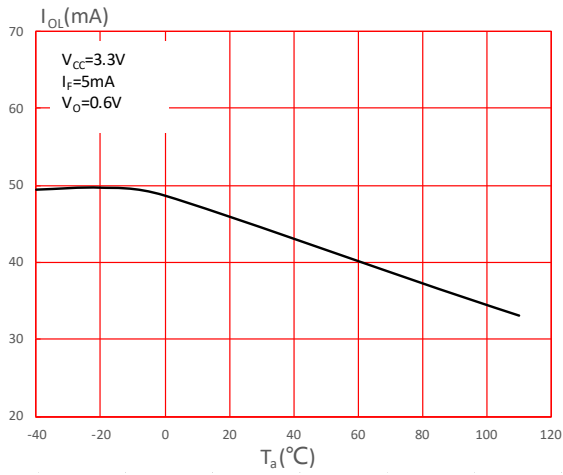


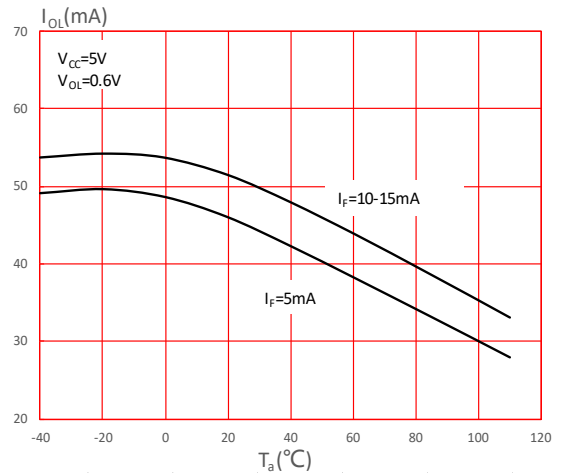
FIG.6: Low Level Output Voltage vs. Ambient Temperature



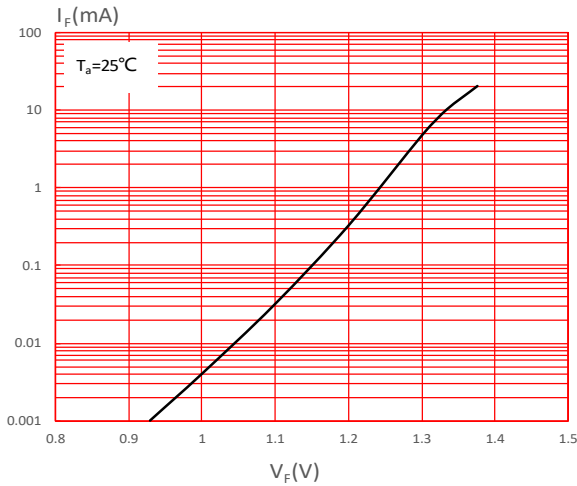
**FIG.7:** Low Level Output Current vs. Ambient Temperature



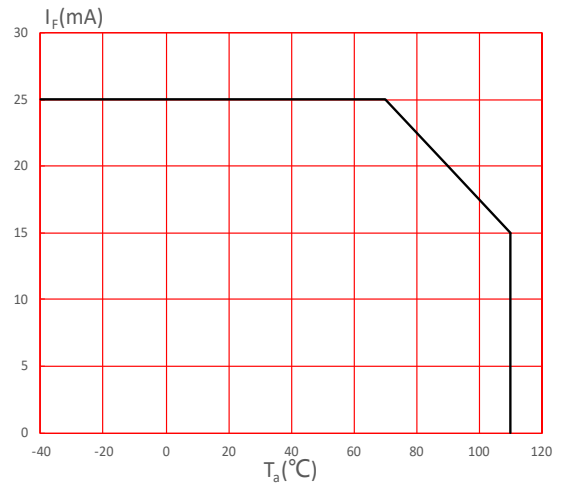
**FIG.8:** Low Level Output Current vs. Ambient Temperature



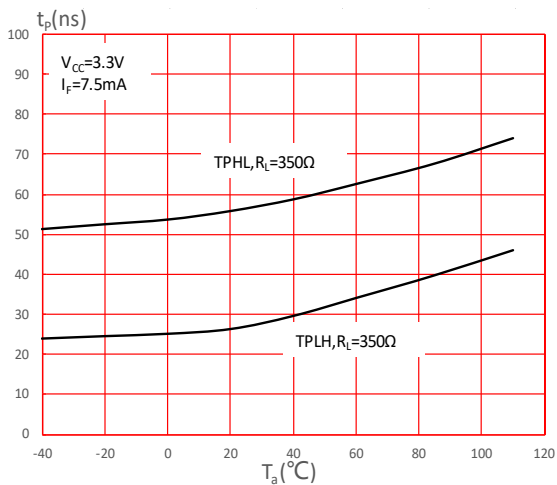
**FIG.9:** Input Forward Current vs. Input Forward Voltage



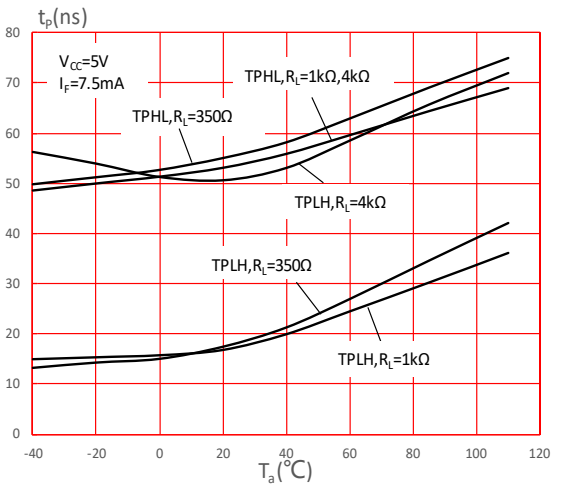
**FIG.10:** Forward Voltage Max. Allowable LED Forward Current vs. Ambient Temperature



**FIG.11:** Propagation Delay vs. Ambient Temperature

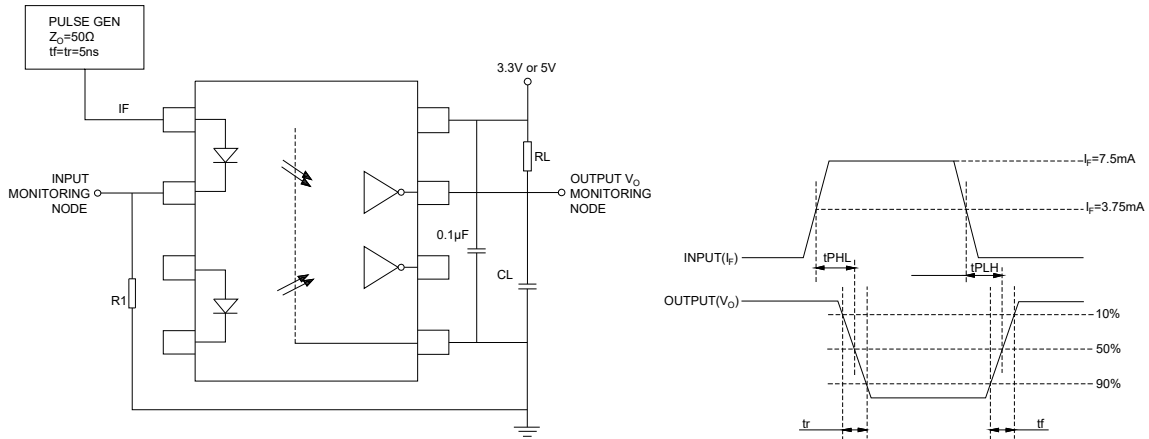


**FIG.12:** Propagation Delay vs. Ambient Temperature

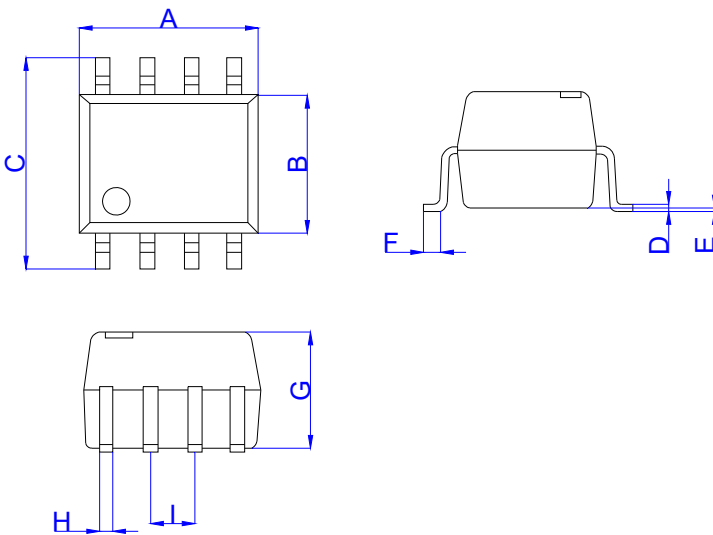


TEST CIRCUITS

Fig.13: Test Circuit for TPHL and TPLH

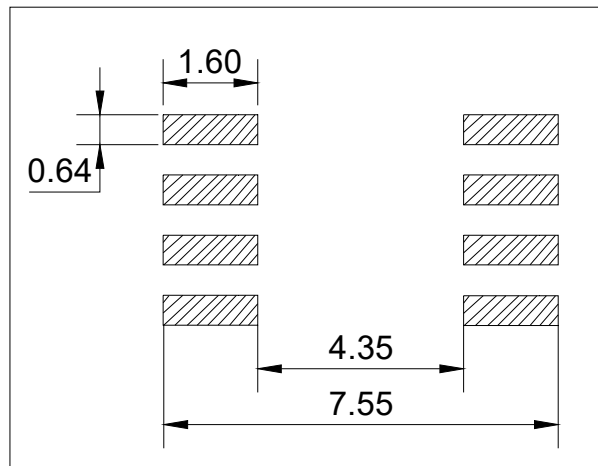


Package Dimension (Unit: mm)

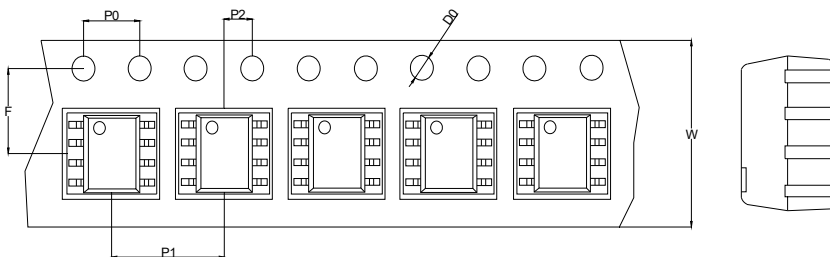


Ref.	Dimensions					
	Millimeters			Inches		
	Min.	Typ.	Max.	Min.	Typ.	Max.
A	4.93		5.33	0.194		0.210
B	3.80		4.10	0.150		0.161
C	5.70		6.30	0.224		0.248
D	0.15		0.25	0.006		0.010
E	0.00		0.20	0.000		0.008
F	0.305		0.50	0.012		0.020
G	3.20		3.40	0.126		0.134
H	0.30		0.50	0.012		0.020
I	1.17		1.37	0.046		0.054

**RECOMMENDED SOLDER MASK (Dimensions in mm unless otherwise stated)**

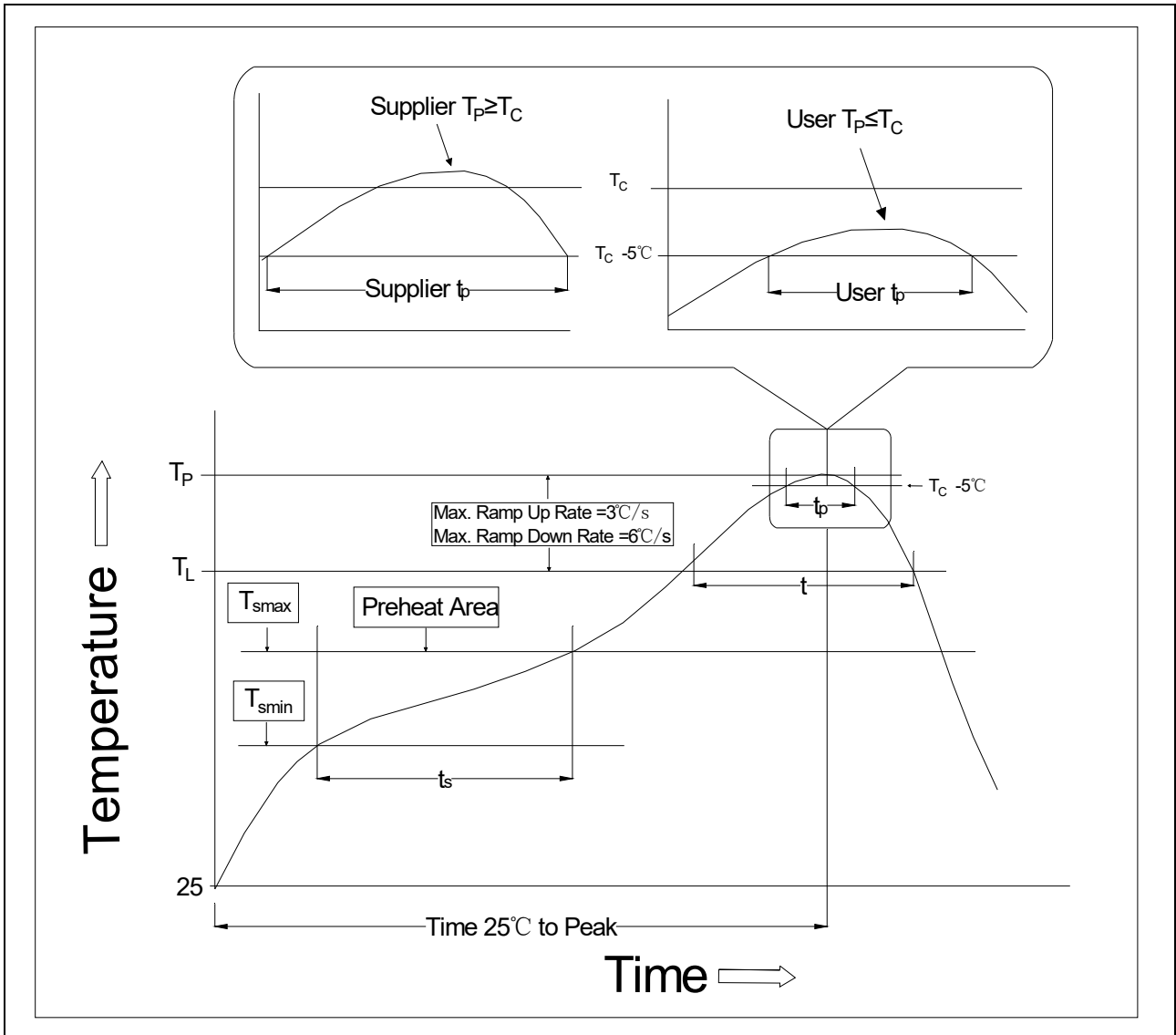


**CARRIER TAPE SPECIFICATIONS (Dimensions in mm unless otherwise stated)**



Ref.	Dimensions					
	Millimeters			Inches		
	Min.	Typ.	Max.	Min.	Typ.	Max.
D0	1.40	1.50	1.60	0.055	0.059	0.063
P0	3.90	4.00	4.10	0.154	0.157	0.161
P1	7.90	8.00	8.10	0.311	0.315	0.319
P2	1.90	2.00	2.10	0.075	0.079	0.083
F	5.40	5.50	5.60	0.213	0.217	0.220
W	11.70	12.00	12.30	0.461	0.472	0.484

REFLOW INFORMATION




Profile Feature	Sn-Pb Assembly Profile	Pb-Free Assembly Profile
Temperature Min. (T <sub>smin</sub> )	100°C	150°C
Temperature Max. (T <sub>smax</sub> )	150°C	200°C
Time (t <sub>s</sub> ) from (T <sub>smin</sub> to T <sub>smax</sub> )	60-120 seconds	60-120 seconds
Ramp-up Rate (t <sub>L</sub> to t <sub>P</sub> )	3°C/second max.	3°C/second max.
Liquidus Temperature (T <sub>L</sub> )	183°C	217°C
Time (t <sub>L</sub> ) Maintained Above (T <sub>L</sub> )	60-150 seconds	60-150 seconds
Peak Body Package Temperature	235°C+0°C/-5°C	260°C+0°C/-5°C
Time (t <sub>P</sub> ) within 5°C of 260°C	10 seconds	10 seconds
Ramp-down Rate (T <sub>P</sub> to T <sub>L</sub> )	3-6°C/second	3-6°C/second
Time 25°C to Peak Temperature	6 minutes max.	8 minutes max.

Note:

1. Reflow soldering is recommended at the temperatures and times shown, no more than three times.
2. Avoid direct contact between the epoxy body and any tools or surfaces exceeding its maximum storage temperature.
3. Application of pressure on the epoxy body is prohibited at elevated temperatures. In specific scenarios, any applied force must not exceed 2.5N.
4. Ensure the component has cooled to ambient temperature before proceeding with any subsequent manufacturing steps.
5. The component has a shelf life of one year when stored under standard conditions.
6. Recommend storage Temp.: 0~40°C;  
Recommend storage humidity: <60%;  
MSL level: MSL 1

Information furnished in this document is believed to be accurate and reliable. However, Jiangsu JieJie Microelectronics Co., Ltd. assumes no responsibility for the consequences of use without consideration for such information nor use beyond it. Information mentioned in this document is subject to change without notice, apart from that when an agreement is signed, Jiangsu JieJie complies with the agreement.

Products and information provided in this document have no infringement of patents. Jiangsu JieJie assumes no responsibility for any infringement of other rights of third parties which may result from the use of such products and information. This document supersedes and replaces all information previously supplied.

 is a registered trademark of Jiangsu JieJie Microelectronics Co., Ltd.

Copyright © 2026 Jiangsu JieJie Microelectronics Co., Ltd. All rights reserved.